

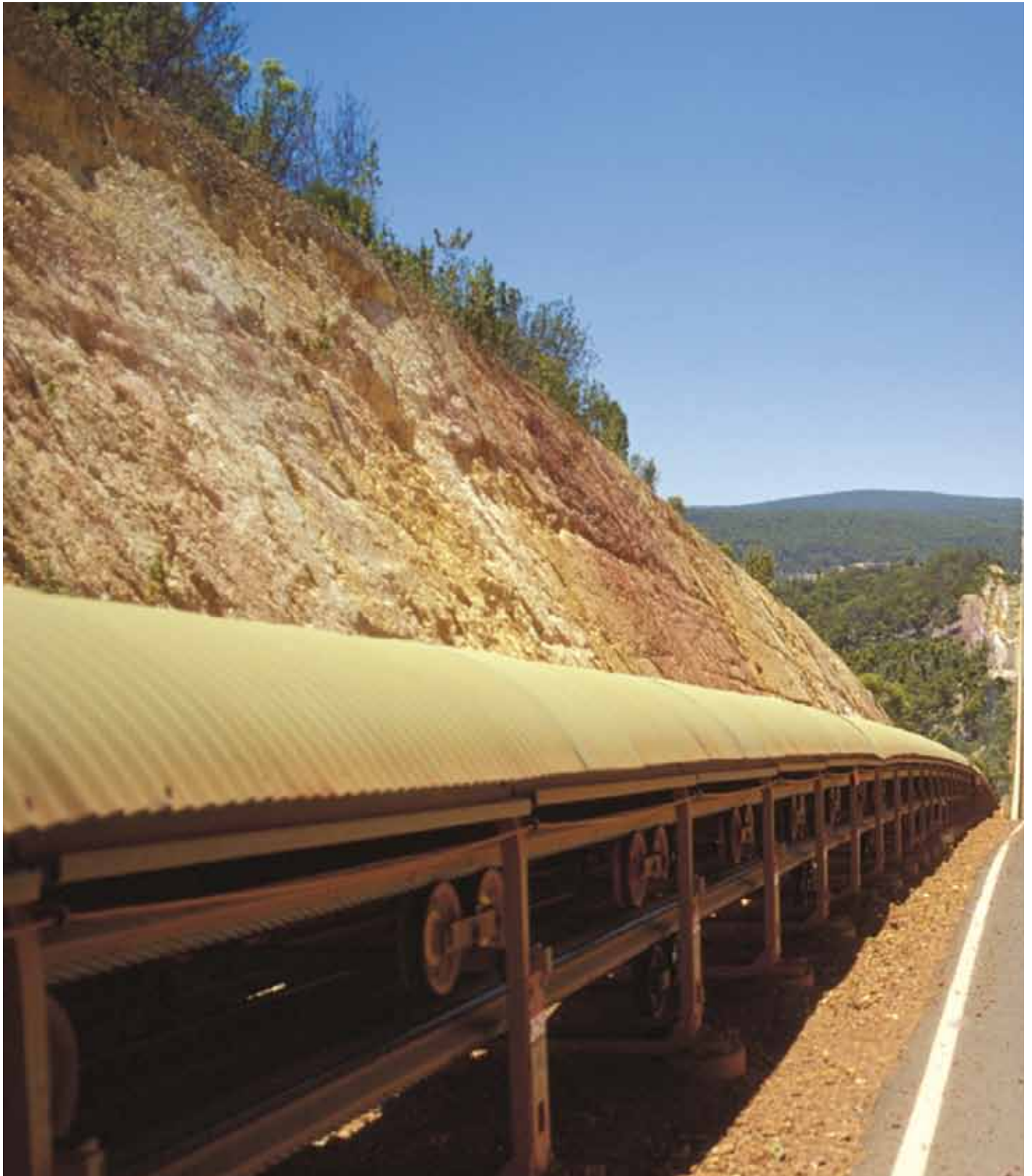

Product brochure

Medium voltage AC drive

ACS 1000, ACS 1000i
315 kW – 5 MW, 2.3 – 4.16 kV



Retrofit-ready simplicity

The ACS 1000 family is optimized for retrofits. With its network-friendly diode rectifiers, the motor-friendly output sine filter and its input transformer flexibility, it can fit where you need it.

Network friendly

Depending on the network conditions, the drives of the ACS 1000 family can be equipped with a 12- or 24-pulse diode rectifier which meets the stringent requirements for current and voltage harmonic distortion as defined by IEEE, IEC and EN. This eliminates the need for costly harmonic analysis or installation of network filters when applying a new drive.

Output sine filter – perfect for standard motors and retrofit applications

Voltage reflections and common mode voltages, caused by any inverter topology, are a real concern for medium voltage motors. They cause excessive stress to a standard motor insulation and create harmful bearing currents, both with potentially disastrous consequences. Furthermore, the motor is subjected to additional harmonic heating generated by the inverter switching if no further precautions are taken.

With an ACS 1000 or ACS 1000i, all these detrimental effects are totally eliminated by its unique output sine filter, being an integral part of the drive. The result is an excellent waveform of voltage and current, supplied to the motor.

Benefits

- Compatibility with standard induction motors without derating
- Ability to retrofit to existing motors
- Motor efficiency same as Direct-On-Line (DOL) operation
- Reduced motor noise
- Use of standard cables
- No limitation of motor cable length

System design flexibility

The ACS 1000 family can be configured with either an integrated dry-type or separately installed input transformer. This flexibility enables the use of oil-filled transformers when the transformer will be mounted outdoors. The advantage is that heat losses from the input transformer are not dissipated in the electrical room. The integrated input transformer, on the other hand, simplifies installation and commissioning (three cables in - three cables out).

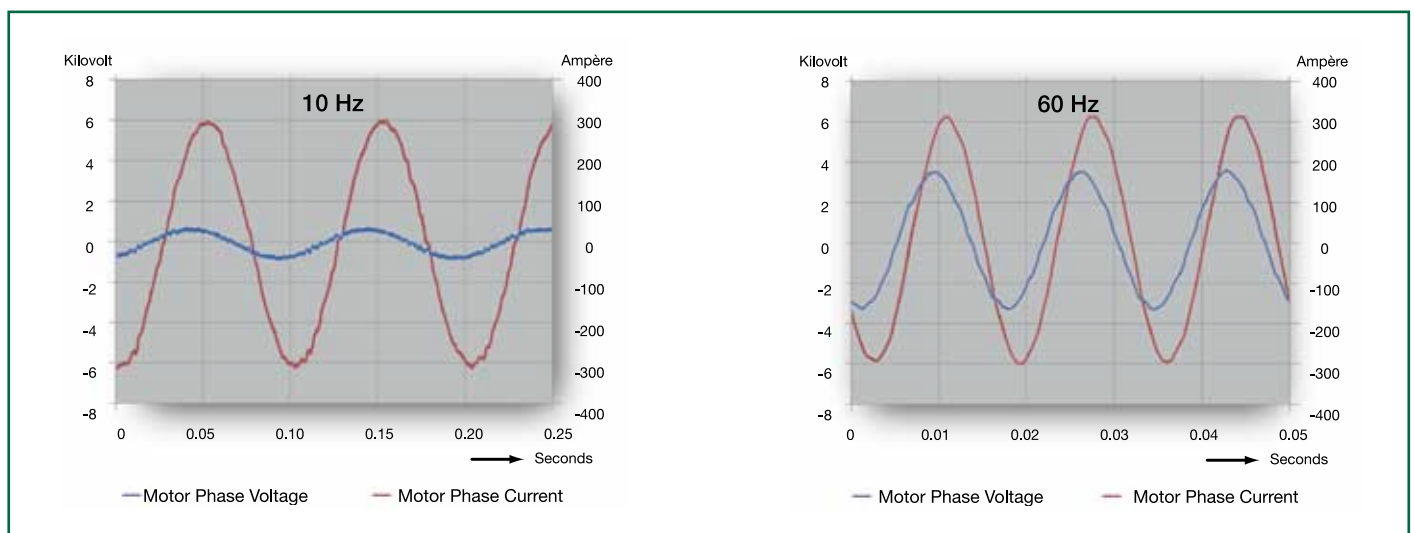

The ACS 1000 drives family provides smooth and accurate motor control even at low speed and full torque (left diagram: 10 Hz, 100% torque) throughout the full operating range of speed and load (right diagram: 60 Hz, 100% torque).

Reliable and efficient components

Reliable components

IGCT semiconductors

The ACS 1000 and ACS 1000i use a power semiconductor known as IGCT (Integrated Gate Commutated Thyristor), which is an ideal switch for high-powered medium voltage applications. The use of IGCTs results in low parts count, providing an efficient and reliable drive.

Fuseless

The converter design does not require any medium voltage power fuses, which are known to be unreliable, costly and subject to aging. The ACS 1000 and ACS 1000i use dedicated IGCTs, instead, which provide faster and better protection for the power components.

Long-life capacitors

Electrolytic capacitors, which have a poor life expectancy, are not used in the ACS 1000 and ACS 1000i. Advanced, environmental friendly, rapeseed oil-filled foil capacitors, designed for a long lifetime, are used instead.

Powerful motor control platform

The motor control platform of the ACS 1000 drives family is ABB's award-winning Direct Torque Control (DTC). It provides rapid, accurate and stepless control from zero to full speed and can deliver full torque with optimal speed accuracy over the whole speed range, even without encoder.

Power loss ride through

A special feature of DTC is its ability to ride through short main supply voltage interruptions so that in most cases the process is not affected.

High level of personal safety

Electric arcs represent a hazard source for people and goods. For systems where large and dangerous arc fault currents can occur, special attention is required.

Therefore, the ACS 1000 and ACS 1000i fulfill the IAC requirements for arc containment assuring personal safety. For higher currents, the ACS 1000 cabinet can be equipped with a pressure relief flap. Optionally, the ACS 1000 and ACS 1000i are available with ABB's Arc Guard System™ for very fast arc detection.

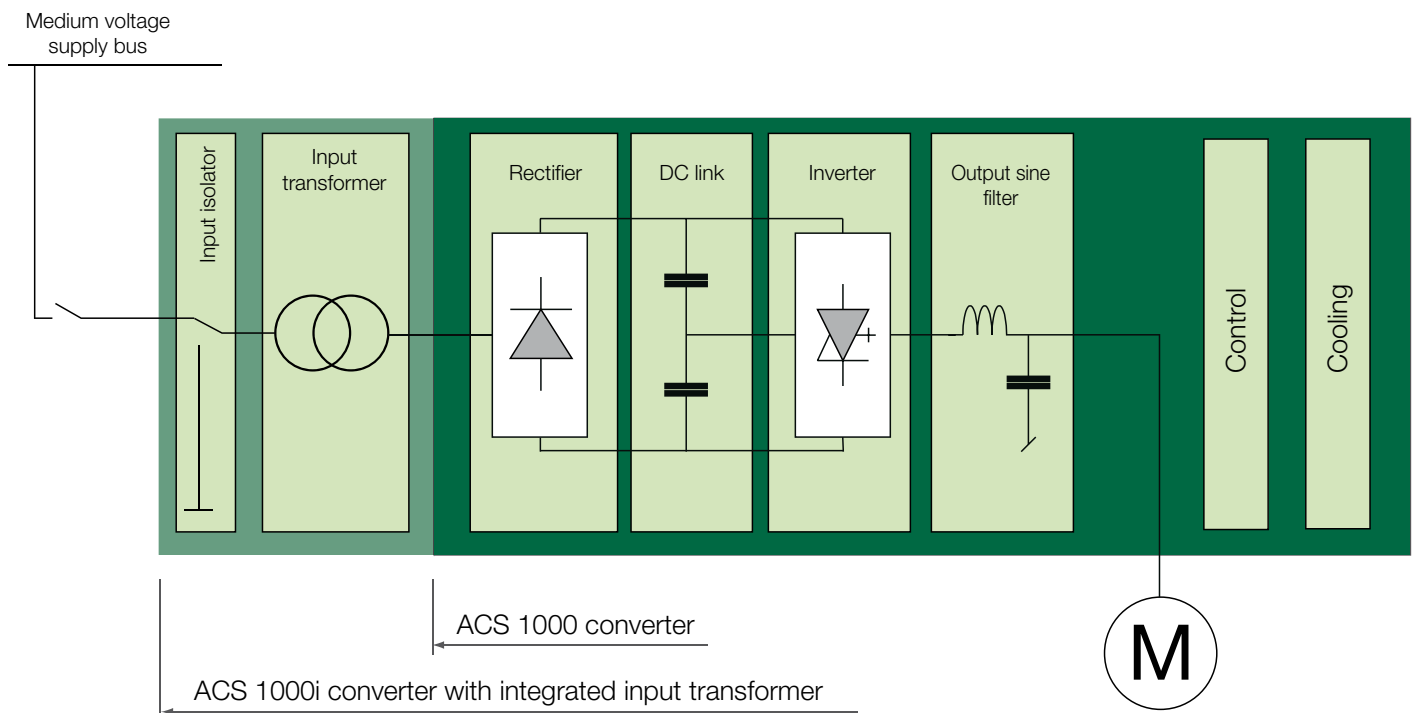

The ACS 1000 drives family's well proven three-level inverter, without series or parallel connected power semiconductors, is one of the least complex, most robust and efficient drive topologies.

ACS 1000 air cooled



Cable connection section for top and bottom entry/exit

Integrated fan for low noise level

IGCT power semiconductors



Control electronics mounted on swing frame

Application and motor control board with fast digital signal processor and DTC

Fiber optics for noise immunity and galvanic isolation

12-pulse input bridge as standard

24-pulse input bridge as option

Output filter capacitor

ACS 1000 water cooled



Cable connection section for top and bottom entry/exit

IGCT inverter stacks on swing frame for easy access



Control electronics mounted on swing frame

Application and motor control board with fast digital signal processor and DTC

Fiber optics for noise immunity and galvanic isolation

Output filter choke

12-pulse input bridge as standard

24-pulse input bridge as option

Water cooling cabinet with heat exchangers and deionization unit

ACS 1000i air cooled with integrated input transformer and input contactor (optional)



Input isolator

Fused input contactor (optional)

24-pulse input transformer

3-level voltage source inverter using IGCT power semiconductors



Power cable connection section for top and bottom entry

24-pulse input bridge as standard

Control electronics mounted on swing frame

DC link capacitor

Application and motor control board with fast digital signal processor and DTC

Fiber optics for noise immunity and galvanic isolation

Features and benefits

Features	Advantages	Benefits
Flexible input transformer configuration	The air cooled drives of the ACS 1000 family are available with integrated or separate input transformer, which can be placed outside the electrical room.	<ul style="list-style-type: none"> – Integrated transformer for quick installation and commissioning – Separate transformer reduces the air-conditioning requirements. The losses from the transformer do not dissipate into the electrical room
Network and motor friendliness	<p>The 12-/24-pulse rectifier meets the most stringent requirements of international standards for current and voltage harmonic distortion.</p> <p>The sine filter gives an excellent output waveform, eliminating harmonics and common mode voltage and reducing stress on the motor.</p>	<p>Minimum network harmonics to avoid system interferences and utility penalties</p> <ul style="list-style-type: none"> – Elimination of voltage stresses for a longer motor lifetime – Motors can be used without derating and long cable runs between motor and drive are not a problem
Reliable and efficient components	<p>ABB's IGCT high power switching device results in low parts count, providing an efficient and reliable converter.</p> <p>The cooling equipment is available with redundant fans or pumps.</p>	High reliability for minimum downtime
Direct Torque Control (DTC)	<p>The fast control provided by Direct Torque Control (DTC) allows optimum process control and exact motor performance with minimum torque ripple and lowest energy consumption</p> <p>A special feature of DTC is its ability to ride through short main supply voltage interruptions</p>	<p>Fast, accurate and robust process control for constant product quality, minimum raw material waste and minimum machinery wear</p> <p>Power loss ride through</p>
Simple access	The ACS 1000 and ACS 1000i have been designed to allow easy front access	Simple and efficient maintenance
Arc protection	The ACS 1000 and ACS 1000i are IAC classified	High level of personal safety
DriveMonitor™ (optional)	DriveMonitor™ provides monitoring access to the drive even from remote locations	User-friendly drive monitoring and remote diagnostics
Service and support	ABB, the largest drives supplier worldwide, has a global support network, which provides assistance and spare parts 24 hours/day, 365 days/year	Around the clock access to drive specialists and spare parts

Simple drive system integration

The ACS 1000 and ACS 1000i allow smooth and simple system integration into the customer's industrial environment.

Flexible control interface

ABB offers an open communication strategy, enabling connection to higher-level process controllers. The ACS 1000 and ACS 1000i can be installed with all major fieldbus adapters for smooth integration, monitoring and controlling of different processes, according to customer requirements.

DriveOPC

DriveOPC is a software package, which allows communication between ABB drives and the customer's Windows®-based applications.

Benefits

- Standard interface
- Remote connection via LAN (Local Area Network)
- Access to:
 - drive control
 - signals and parameters
 - data and fault loggers

Monitoring and diagnostics

The ACS 1000 and ACS 1000i are available with an intelligent remote monitoring and diagnostics system, which allows secure access to the drive from any location in the world.

DriveMonitor™ allows real-time access to the drive. It supports monitoring and diagnostics of ABB drives for new and existing installations.

The optional tool consists of a hardware module, as well as a software layer that automatically collects and analyzes selected drive signals and parameters.

Long-term monitoring functions deliver important information on equipment status, maintenance tasks needed and possible performance improvements. Diagnostic procedures and trending can cover not only the converter itself but other parts of the shaft train as well.

Benefits

- Early detection to avoid costly repairs
- Reduction of process-critical faults
- Optimization of maintenance cost and schedule over the product life cycle
- Long-term statistics for optimization of process performance
- Easier root cause analysis – reduced Mean Time To Repair (MTTR)

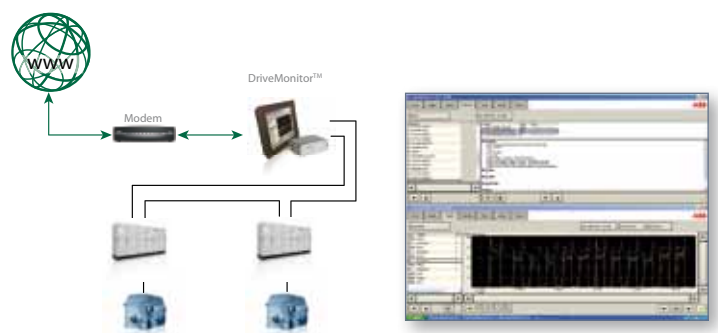

Data sheet ACS 1000i with integrated transformer

Motor data			Converter	Converter data			
Voltage **	Shaft power *		Type code	Power	Current *	Length	Weight ***
kV	kW	hp		kVA	A	mm	kg
3'300 V - air cooled							
3.3	315	420	ACS 1043-A1-A	400	70	3300	3900
3.3	355	480	ACS 1043-A1-B	450	79	3300	3900
3.3	400	540	ACS 1043-A1-C	500	87	3300	3900
3.3	450	600	ACS 1043-A1-D	550	96	3300	3900
3.3	500	670	ACS 1043-A1-E	600	105	3300	3900
3.3	560	750	ACS 1043-A1-F	700	122	3300	4300
3.3	630	840	ACS 1043-A2-G	750	131	3300	4300
3.3	710	950	ACS 1043-A2-H	850	149	3300	4300
3.3	800	1'070	ACS 1043-A2-J	950	166	3300	4300
3.3	900	1210	ACS 1043-A2-K	1100	192	3300	4300
3.3	1000	1340	ACS 1043-A2-L	1200	210	3300	5100
3.3	1120	1500	ACS 1043-A3-M	1350	236	3300	5100
3.3	1250	1680	ACS 1043-A3-N	1500	262	3300	5100
3.3	1400	1880	ACS 1043-A3-P	1700	297	3300	5500
3.3	1500	2010	ACS 1043-A3-Q	1900	332	3300	5500
4'000 V / 4'160 V - air cooled							
4.0	300	400	ACS 1044-A1-A	400	58	3300	4000
4.0	340	450	ACS 1044-A1-B	400	58	3300	4000
4.0	370	500	ACS 1044-A1-C	450	65	3300	4000
4.0	450	600	ACS 1044-A1-D	550	79	3300	4000
4.0	520	700	ACS 1044-A1-E	650	94	3300	4000
4.0	600	800	ACS 1044-A1-F	750	108	3300	4000
4.0	670	900	ACS 1044-A1-G	800	115	3300	4000
4.0	750	1000	ACS 1044-A1-H	900	130	3300	4000
4.0	930	1250	ACS 1044-A2-J	1150	166	3300	4900
4.0	1120	1500	ACS 1044-A2-K	1350	195	3300	4900
4.0	1300	1750	ACS 1044-A3-L	1550	224	3300	5600
4.0	1490	2000	ACS 1044-A3-M	1800	260	3300	5600
4.0	1680	2250	ACS 1044-A3-N	2000	289	3300	5600
4.0	2010	2700	ACS 1044-A3-P	2330	347	3300	5600

Notes:

- * Indicative information only.
- ** Higher output voltages available with step-up transformer.
- *** Weight indications are approximate; based on 6.0 – 6.6 kV/50 Hz line supply voltage.

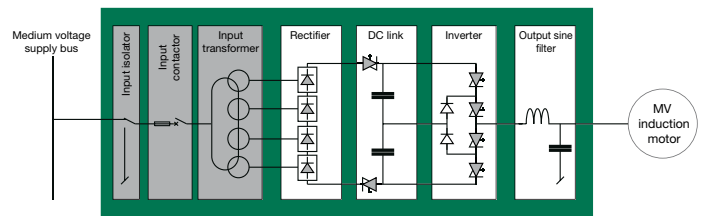

Typical ACS 1000i diagram

General dimension	Frame size A1	Frame size A2/A3
Cabinet height	2050 mm (6 ft 7 in) excl. cooling fans	2150 mm (7 ft 1 in) excl. cooling fans
	2517 mm (8 ft 3 in) incl. fan hood	2562 mm (8 ft 4 in) incl. fan hood
	2617 mm (8 ft 6 in) incl. redundant fan hood and/or IP 42	2662 mm (8 ft 7 in) incl. redundant fan hood and/or IP 42
Cabinet depth	1121 mm (3 ft 8 in)	1121 mm (3 ft 8 in)

Data sheet ACS 1000 for induction motors (external transformer)

Motor data			Converter	Converter data			
Voltage **	Shaft power *		Type code	Power	Current *	Length	Weight ***
kV	kW	hp		kVA	A	mm	kg
2'300V - air cooled							
2.3	300	400	ACS 1012-A1-A	400	100	3000	1600
2.3	340	450	ACS 1012-A1-B	400	100	3000	1600
2.3	370	500	ACS 1012-A1-C	450	113	3000	1600
2.3	450	600	ACS 1012-A1-D	550	138	3000	1600
2.3	520	700	ACS 1012-A1-E	650	163	3000	1600
2.3	600	800	ACS 1012-A1-F	750	188	3000	1600
2.3	670	900	ACS 1012-A1-G	800	201	3000	1600
2.3	750	1000	ACS 1012-A1-H	900	226	3000	1600
2.3	930	1250	ACS 1012-A2-J	1150	289	3000	1750
2.3	1120	1500	ACS 1012-A2-K	1350	339	3000	1750
2.3	1300	1750	ACS 1012-A3-L	1550	389	3000	2000
2.3	1490	2000	ACS 1012-A3-M	1800	452	3000	2000
2.3	1680	2250	ACS 1012-A3-N	2000	502	3000	2000
3'300V - air cooled							
3.3	315	420	ACS 1013-A1-A	400	70	3000	1600
3.3	355	480	ACS 1013-A1-B	450	79	3000	1600
3.3	400	540	ACS 1013-A1-C	500	87	3000	1600
3.3	450	600	ACS 1013-A1-D	550	96	3000	1600
3.3	500	670	ACS 1013-A1-E	600	105	3000	1600
3.3	560	750	ACS 1013-A1-F	700	122	3000	1600
3.3	630	840	ACS 1013-A1-G	750	131	3000	1600
3.3	710	950	ACS 1013-A1-H	850	149	3000	1600
3.3	800	1070	ACS 1013-A2-J	950	166	3000	1750
3.3	900	1210	ACS 1013-A2-K	1100	192	3000	1750
3.3	1000	1340	ACS 1013-A2-L	1200	210	3000	1750
3.3	1120	1500	ACS 1013-A2-M	1350	236	3000	1750
3.3	1250	1680	ACS 1013-A2-N	1500	262	3000	1750
3.3	1400	1880	ACS 1013-A2-P	1700	297	3000	1750
3.3	1600	2150	ACS 1013-A3-Q	1900	332	3000	2000
3.3	1800	2410	ACS 1013-A3-R	2150	376	3000	2000
3.3	2000	2680	ACS 1013-A3-S	2400	420	3000	2000
3'300V - water cooled							
3.3	2000	2680	ACS 1013-W1-S	2400	420	4200	3300
3.3	2250	3020	ACS 1013-W1-T	2700	472	4200	3300
3.3	2500	3350	ACS 1013-W1-U	3000	525	4200	3300
3.3	2800	3750	ACS 1013-W2-V	3350	586	4700	3680
3.3	3150	4220	ACS 1013-W2-W	3750	656	4700	3680
3.3	3550	4760	ACS 1013-W2-X	4250	744	4700	3680
3'300V - water cooled							
3.3	4000	5360	ACS 1013-W3-Y	4750	831	4700	3680
3.3	4500	6030	ACS 1013-W3-Z	5350	936	4700	3680
3.3	5000	6710	ACS 1013-W3-1	5950	1041	4700	3680

Data sheet ACS 1000 for induction motors (external transformer) continued

Motor data			Converter	Converter data			
Voltage **	Shaft power *		Type code	Power	Current *	Length	Weight ***
kV	kW	hp		kVA	A	mm	kg
4'000 V - air cooled							
4.0	300	400	ACS 1014-A1-A	400	58	3000	1600
4.0	340	450	ACS 1014-A1-B	400	58	3000	1600
4.0	370	500	ACS 1014-A1-C	450	65	3000	1600
4.0	450	600	ACS 1014-A1-D	550	79	3000	1600
4.0	520	700	ACS 1014-A1-E	650	94	3000	1600
4.0	600	800	ACS 1014-A1-F	750	108	3000	1600
4.0	670	900	ACS 1014-A1-G	800	115	3000	1600
4.0	750	1000	ACS 1014-A1-H	900	130	3000	1600
4.0	930	1250	ACS 1014-A2-J	1150	166	3000	1750
4.0	1120	1500	ACS 1014-A2-K	1350	195	3000	1750
4.0	1300	1750	ACS 1014-A3-L	1550	224	3000	2000
4.0	1490	2000	ACS 1014-A3-M	1800	260	3000	2000
4.0	1680	2250	ACS 1014-A3-N	2000	289	3000	2000
4.0	1860	2500	ACS 1014-A3-P	2300	330	3000	2000
4'000 V - water cooled							
4.0	1860	2500	ACS 1014-W1-P	2300	332	4200	3300
4.0	2240	3000	ACS 1014-W1-Q	2700	390	4200	3300
4.0	2610	3500	ACS 1014-W2-R	3100	447	4700	3680
4.0	2980	4000	ACS 1014-W2-S	3600	520	4700	3680
4.0	3360	4500	ACS 1014-W2-T	4000	577	4700	3680
4.0	3730	5000	ACS 1014-W2-U	4500	650	4700	3680
4.0	4100	5500	ACS 1014-W3-V	4900	707	4700	3680
4.0	4470	6000	ACS 1014-W3-W	5300	765	4700	3680
4.0	5250****	7035	ACS 1014-W3-X	6090	879	4700	3680

Notes:

- * Indicative information only.
- ** Higher output voltages available with step-up transformer.
- *** Weight indications are approximate.
- **** Motor shaft power up to 5600 kW is available on request.

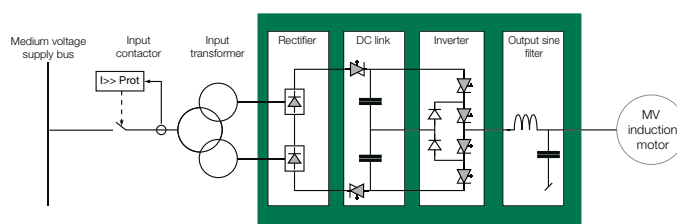

Typical ACS 1000 diagram

General dimension	Air cooled	Water cooled
Cabinet height	2005 mm (6 ft 6 in)	2020 mm (6 ft 6 in)
	2070 mm (6 ft 8 in) incl. lifting eyes	2070 mm (6 ft 8 in) incl. lifting eyes
	2285 mm (7 ft 6 in) incl. air exhaust hood	
Cabinet depth	900 mm (3 ft)	900 mm (3 ft)

