

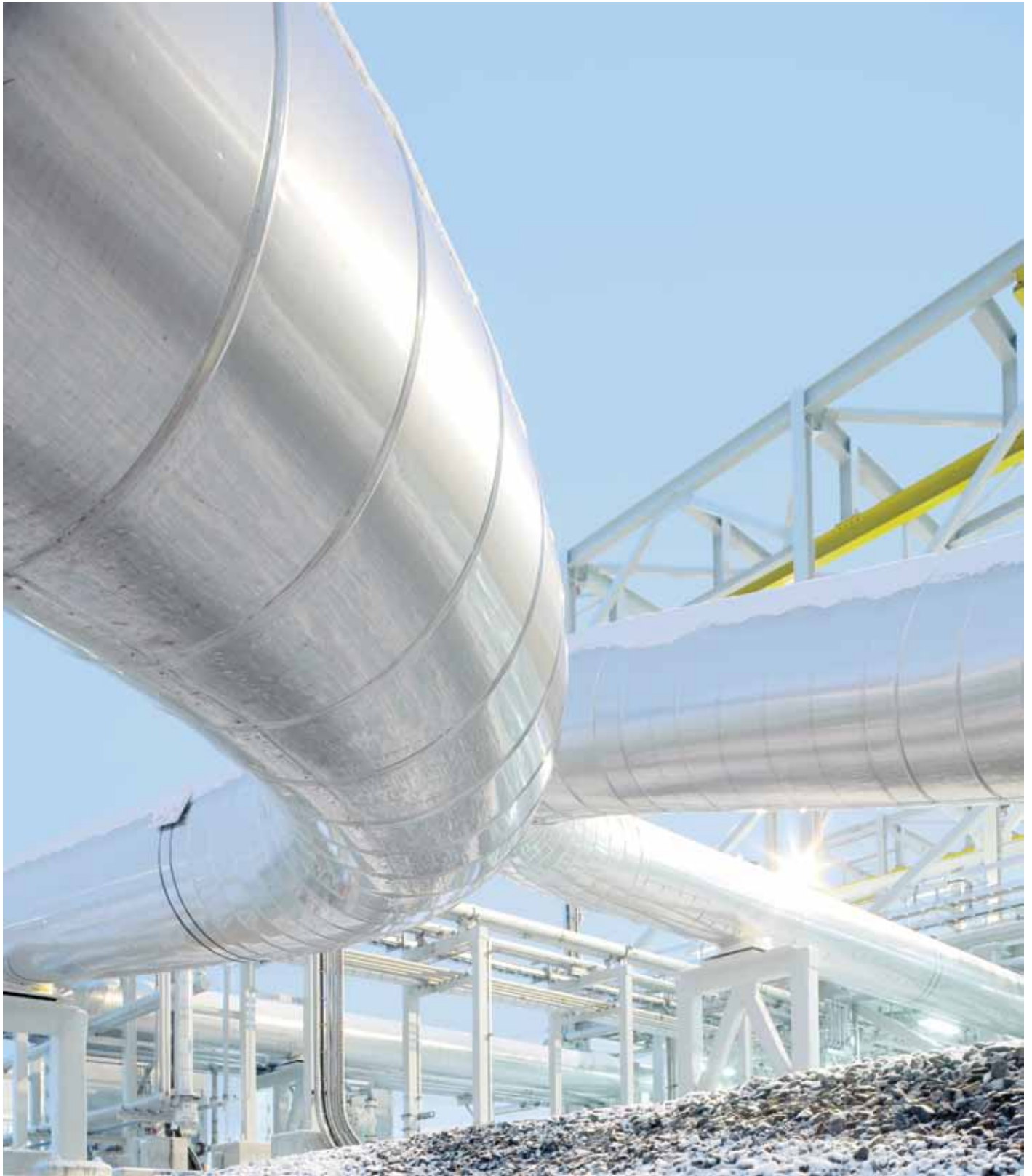

Product brochure

Medium voltage AC drive ACS 2000, 250 – 2500 kW, 4.0 – 6.9 kV



ACS 2000 – simple and reliable motor control

The ACS 2000 medium voltage AC drive provides reliable motor control for a wide range of applications.

The ACS 2000 is designed for high reliability, easy installation and fast commissioning reducing the total cost of ownership.

With its compact footprint, the ACS 2000 can be retrofitted to control standard induction motors via a direct connection to 4.0 – 6.9kV line supplies (direct-to-line). Alternatively, the ACS 2000 can be operated with an input isolation transformer to allow for flexible line side power voltages. It is available with an integrated transformer or it can be connected to an external transformer.

The ACS 2000 direct-to-line combines the cost savings of a transformerless variable speed drive system with the benefits of Voltage Source Inverters (VSIs), including excellent availability and reliability, high and constant power factor and superior dynamic control performance.

The ACS 2000 is available as low harmonic drive for optimal low harmonic performance or as regenerative drive for enhanced active braking and power factor correction.

Key product features

- Suitable for use with or without an input isolation transformer
- Direct-to-line connection (transformerless) provides low cost of ownership
- Simple drive system integration
- Three in - three out cabling technique for quick and easy installation
- Suitable for new or existing induction motors
- Modular design provides high reliability and low maintenance costs
- ACS 2000, low harmonic drive for low harmonic performance
- ACS 2000, regenerative drive for regeneration and power factor correction

Fields of application

Industries	Applications
Cement, mining and minerals	Conveyors, crushers, mills, mine hoists, fans and pumps
Chemical, oil and gas	Pumps, compressors, extruders, mixers and blowers
Metals	Fans and pumps
Pulp and paper	Fans, pumps, refiners, vacuum pumps and chippers
Power generation	Fans, pumps, conveyors and coal mills
Water	Pumps
Other applications	Test stands, wind tunnels and sugar mills

Key features

The ACS 2000 general purpose drive offers unique features which provide superior application flexibility with a standard solution.

Line supply connection flexibility

The ACS 2000 provides different line supply connection options, each offering unique benefits. The ACS 2000 is available for connection to an external input isolation transformer, with an integrated input isolation transformer or for use without a transformer. The latter allows a direct connection to the industrial line supply (direct-to-line).

Direct-to-line

The ACS 2000 direct-to-line features an Active Front End (AFE), which enables transformerless operation. This can lower investment costs substantially. Due to its compact size and lighter weight compared to a drive requiring a transformer, it also results in lower transportation costs and needs less space in the electrical room.

The ACS 2000 can be easily retrofitted to fixed speed motors while the direct-to-line technology results in quick and easy installation and commissioning.

For operation with transformer

External transformer

For applications where a voltage-matching input transformer is needed or galvanic isolation from the power supply is required, the ACS 2000 can be connected to a conventional oil or dry-type converter transformer.

Integrated transformer

Alternatively, the ACS 2000 is also available with an integrated input isolation transformer.

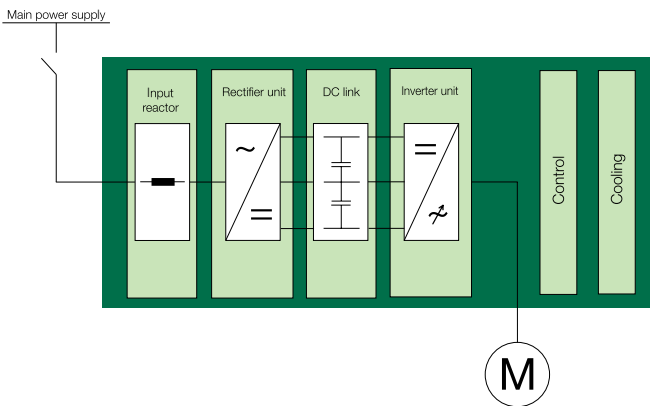

Topology of the ACS 2000 for direct-to-line connection

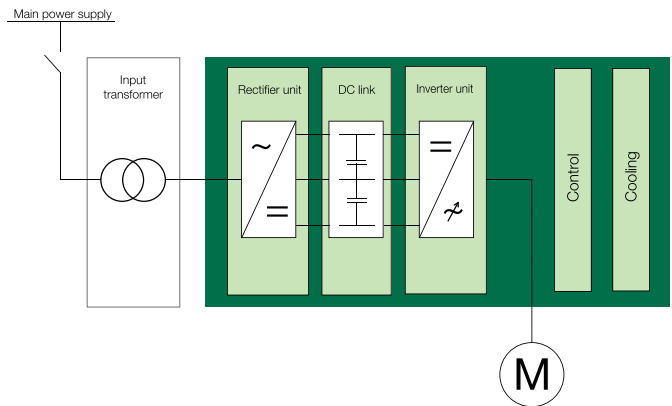

Topology of the ACS 2000 for operation with an external transformer

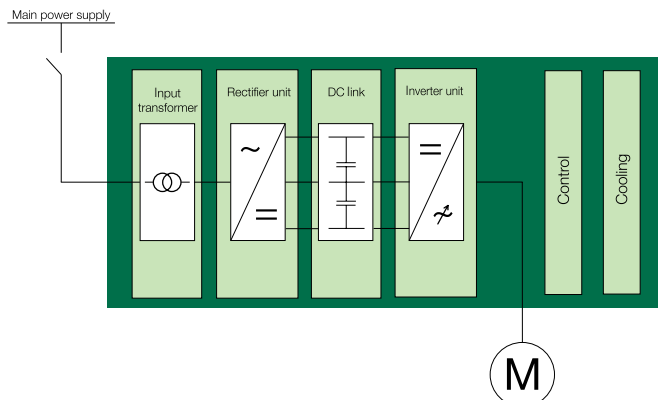

Topology of the ACS 2000 with an integrated input transformer



Powerful performance with DTC

Precise and reliable process control, together with low energy consumption, results in top performance. The ACS 2000 drive control platform uses ABB's award-winning Direct Torque Control (DTC), resulting in the highest torque and speed performance as well as the lowest losses ever achieved in medium voltage AC drives. Control of the drive is immediate and smooth under all conditions.

Motor friendly output waveform for use with new or existing motors

The ACS 2000 provides near sinusoidal current and voltage waveforms making it compatible for use with standard motors and cable insulation. This is achieved with ABB's patented multilevel topology which utilizes one DC link enabling a multi-level output waveform with a minimum number of power components.

Low harmonic signature

A low harmonic solution is available which meets the most stringent requirements for harmonic distortion as defined by relevant standards. This avoids the need for harmonic analysis or the installation of network filters.

Regeneration

For applications with high braking energy, the ACS 2000 is available with optional regeneration capability, which feeds back braking energy to the line supply. This further reduces the overall energy consumption.

Power factor correction

For applications where other loads connected to the same line supply cause leading or lagging power factor, the ACS 2000 is available with a static VAR compensation option. With static VAR compensation, a smooth line supply voltage profile can be maintained and reactive power penalties can be avoided.

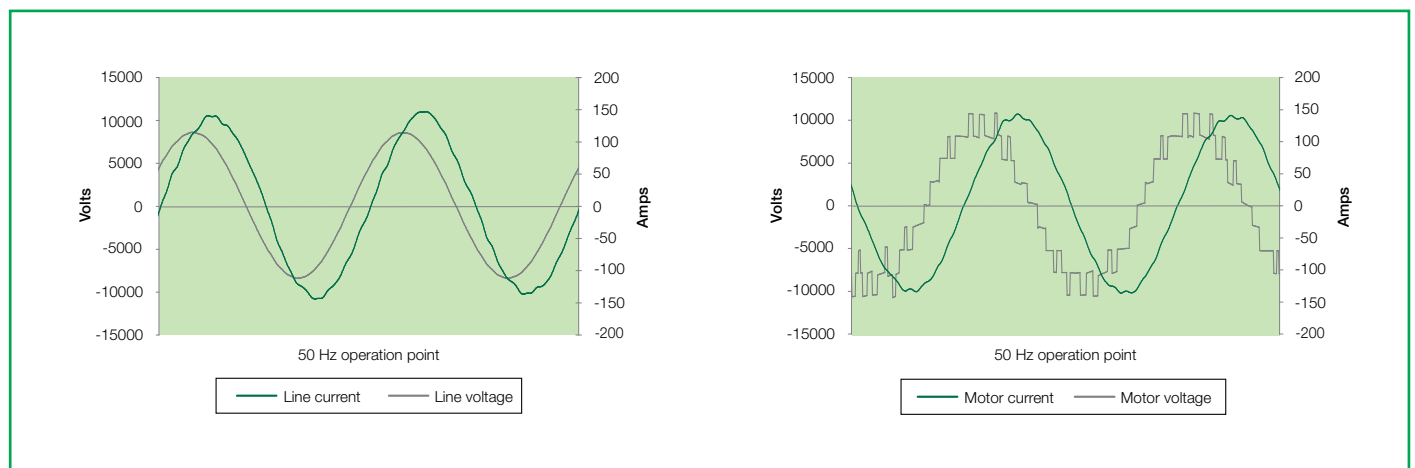

Line and motor current and voltage

ACS 2000 – the right choice for general purpose applications

Depending on the application, variable speed drives have to fulfill different requirements. The ACS 2000 provides the right solution for general purpose applications.

ACS 2000, low harmonic drives

ABB's low harmonic drives offer optimal low harmonic performance which does not require any additional filtering.

Line side harmonics of the ACS 2000 are compliant with all relevant standards. This avoids the need for harmonic analysis or the installation of a multi-pulse transformer, network filters or other additional equipment for harmonics reduction.

ACS 2000, regenerative drives

ACS 2000 regenerative drives feature an Active Front End (AFE), which provides enhanced active braking and power factor correction.

Regenerative braking

The AFE enables regenerative braking which allows full power flow both in motoring and generating mode. Regeneration offers significant energy savings compared to other braking methods as energy is fed back to the supply network.

Regeneration is especially suitable for applications with frequent starts and stops. It allows energy efficient continuous braking of applications such as downhill conveyors or expanders in gas pipelines.

Power factor correction

The AFE can also provide reactive power (VAR) compensation. With VAR compensation, the voltage level can be controlled to stay within tight limits. A smooth network voltage profile can be maintained and reactive power penalties can be avoided.



ACS 2000

The air-cooled general purpose drive provides simple and reliable motor control for a wide range of applications.

ACS 2000 direct-to-line,
800kW, 4.0 – 4.16 kV



Electromechanically interlocked doors for safety

DC bus grounding switch for safety

Input reactor with common mode filter for direct-to-line connection

User-friendly drive control panel for local operation

- Keypad with multi-language display
- Main supply on/off pushbuttons
- Emergency off pushbutton

ACS 2000

It is designed for easy installation, fast commissioning and efficient maintenance reducing the total cost of ownership.

ACS 2000, 800 kW, 6.6 kV,
for operation with an external
transformer



Features and benefits

Features	Advantages	Benefits
Operation without transformer (direct-to-line)		
	No transformer required	Reduces capital expenditure
	Easy retrofit to fixed-speed motors	Minimizes investment
	Easy and fast commissioning	Lowers downtime
	Compact and light drive system	Lowers transportation costs; less space required in electrical room
Operation with transformer		
The ACS 2000 is available with an integrated transformer or for operation with an external transformer	Connection to any voltage level	Easy integration into existing infrastructure
	Conventional oil or dry-type input isolation transformer	No special input isolation transformer required
	Galvanic isolation to the line supply	Operation under single ground fault without impact on the drive
	Separate input isolation transformer can be located outside	Heating losses are not dissipated into electrical room, reducing load on HVAC system
	Integrated transformer for quick installation and commissioning	Lowers downtime
Active Front End (AFE)		
	Power factor adjusted to compensate for reactive power	Reduces energy loss in distribution system, avoiding need for larger cables and utility penalties
	Enables a direct connection to the line supply	Transformer is not required
	Four-quadrant operation (regenerative braking)	Minimizes energy consumption
	Inherent low harmonic signature	Harmonic emissions compliant with all relevant standards
Multilevel topology		
	Patented multilevel topology	Low parts count, which boosts drive availability
	Provides near sinusoidal current and voltage waveforms	Compatible with standard new or existing motors
Voltage Source Inverter (VSI) topology		
	Excellent availability, reliability and efficiency	Higher uptime of plant or process
	High and constant power factor	Eliminates utility penalties
	Superior dynamic control performance	Safe ride through during supply voltage dips and better process control
Direct Torque Control (DTC)		
	Precise and reliable process control with superior performance	Higher productivity
Compact size		
	Requires less space in electrical room	Frees up valuable floor space

Simple drive system integration

Installing a medium voltage AC drive could not be easier with ABB's three in - three out concept. Simply disconnect the direct-on-line cable, connect the drive, and connect the drive to the motor.

Along with its flexible line supply connection options and advanced software tools the ACS 2000 allows smooth and simple drive system integration into any industrial environment.

Flexible control interface

ABB offers an open communication strategy, enabling connection to higher-level process controllers. The ACS 2000 can be installed with all major fieldbus adapters for smooth integration, monitoring and controlling of different processes, according to customer requirements.

DriveOPC

DriveOPC is a software package, which allows communication between ABB drives and the customer's Windows®-based applications.

DriveStartup

The commissioning wizard DriveStartup is an advanced tool which simplifies and speeds-up commissioning, reducing plant downtime considerably.

Configurable disconnect

ABB offers a configurable disconnect option package for a flexible, self-contained switchgear solution where no control coordination is required upstream. It provides a visible blade switch disconnect and integral input contactor with options such as a motor protection relay, control power transformer and other customer controls.

Maintenance

Simple and efficient maintenance is an important factor in keeping operating costs down.



The ACS 2000 is designed to maximize uptime as well as to facilitate quick repair. The modular design lends itself to quick and effective replacement of components, resulting in industry leading Mean Time to Repair (MTTR).

Reliable components

ABB drive technologies, such as the multilevel VSI topology, provide a low parts count, which increases reliability, extends Mean Time Between Failures (MTBF) and improves availability.

Easy access

The ACS 2000 has been designed to allow easy front access to all drive components.

Redundant cooling

The ACS 2000 is available with redundant fans which increases availability.

Service and support

The ACS 2000 is backed by comprehensive service and support, from the customer's initial inquiry throughout the entire life cycle of the drive system.

Installation and commissioning

Proper installation and commissioning of the equipment, done by qualified and certified commissioning engineers, reduces start-up time, increases safety and reliability and decreases life cycle costs. In addition, operators can be given practical training by experienced specialists on site.

With its three in - three out principle, flexible line supply connection options and advanced software tools, such as the commissioning wizard, start-up of the ACS 2000 is easy and fast, thereby minimizing plant downtime.

Life cycle management

ABB's drive life cycle management model maximizes the value of the equipment and maintenance investment by maintaining high availability, eliminating unplanned repair costs and extending the lifetime of the drive.

Life cycle management includes:

- providing spare parts and expertise throughout the life cycle
- providing efficient product support and maintenance for improved reliability
- adding functionality to the initial product
- providing a smooth transition to a new technology at the end of the life cycle

Training

ABB provides extensive training for its medium voltage AC drives. A range of training programs is offered from basic tutorials to programs tailored to the customer's specific needs.

Global network, local presence

Aftersales service is an integral part of providing the customer with a reliable and efficient drive system. The ABB Group of companies operates in more than 100 countries and has a worldwide network of service operations.

Services for ABB's medium voltage AC drives

- Supervision of installation and commissioning
- Local support
- Worldwide service network
- Spare parts and logistics network
- Training
- Remote services
- 24 x 365 technical support
- Preventive maintenance
- Customized service agreements



Data sheet ACS 2000

Inverter type

Voltage Source Inverter (VSI), 9 levels line-to-line, with high voltage IGBT (Insulated Gate Bipolar Transistor) power semiconductors

Motors

Induction motors; 250 – 2,500 kW

Standards

All common standards

4 kV according to EN, IEC, CE, NEMA, IEEE 1566, UL 347A

6 kV according to EN, IEC, CE, NEMA

Input

5-level self-commutated IGBT active front end (AFE) or 24-pulse diode front end (DFE)

	direct-to-line	with integrated transformer	for operation with external transformer
Low harmonic drives	AFE	DFE	DFE
Regenerative drives	AFE	AFE	AFE

Rated input voltages:

4.16 kV, -10% to +10% (-30% with derating)

6.0 / 6.6 kV, -10% to +10% (-30% with derating)

6.9 kV, -10% to +5% (-35% with derating); with DFE 0% to +5%

The ACS 2000 with integrated transformer is available with primary transformer voltages of 6.0, 6.6, 10 and 11 kV (+10% to -10%).

Input frequency 50 / 60 Hz

Auxiliary supply voltage

400, 440, 480 or 600 VAC, 3-phase, 50 / 60 Hz

UPS (Uninterruptible Power Supply) / Single phase control supply

If available, an external UPS can be connected for control power supply, 110 – 240 VAC, single phase or 110/220 VDC. Alternatively, the control can be powered via the auxiliary supply voltage or an internal UPS can be provided.

Output frequency

0 to 75 Hz

Rated output voltage

4.0 – 6.9 kV

Efficiency of converter

up to 97.5%

Input power factor

Controlled to 1 or adjustable to compensate for reactive power of other loads connected to the same network

Ambient temperature

+1 to 40 °C (higher with derating)

Enclosure classes

IP21 to IP42

Control interface (optional)

All common fieldbuses including Profibus, Modbus, DeviceNet, Ethernet, ACS Drivebus, ABB Advant Fieldbus AF100, others

Standard protection functions

Auxiliary voltage fault, overtemperature supervision, overcurrent, short circuit detection, motor overload, motor stall and over-speed protection, communication fault (I/O watchdog), earth fault, main circuit breaker supervision/tripping, emergency off signal supervision

Example options

- Motor supervision I/Os
 - Fault/alarm: overtemperature, vibration of bearings
 - PT 100: winding and bearing temperatures
- Transformer supervision I/Os
 - Fault/alarm: overtemperature, Buchholz
 - PT 100: winding temperatures
- Hardwired signals for remote drive control
 - References: start/stop, speed/torque etc.
 - Status feedback signals: ready/running
 - Analog signals: current/voltage/power etc.
- Redundant cooling fans with automatic switch over for duty cycling and upon fan failure
- ABB DriveWindow service and diagnostic software
- ABB DriveMonitor™ for remote monitoring and diagnostics
- Output sine filter for special requirements, such as motor operation in hazardous atmosphere zone 1 or when motor cable length is extra long
- Configurable disconnect package

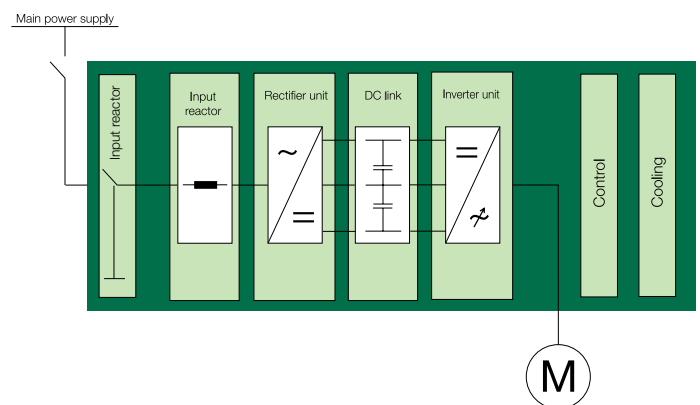

Topology of the ACS 2000 with direct-to-line connection with configurable disconnect

Data sheet ACS 2000, 4.0 – 4.16 kV, low harmonic drive

Motor data ¹							Converter data		Converter length and weight (approx. values)					
									direct-to-line		for operation with external transformer		with integrated transformer	
No overload	Nominal rating		Light overload		Heavy duty		Type code	Power	Length	Weight	Length	Weight	Length	Weight
$P_{cont. max}$	$I_{cont. max}$	I_{max}	P_N	I_N	P_{hd}	I_{hd}		kVA	mm	kg	mm	kg	mm	kg
hp (kW)	A	A	hp (kW)	A	hp (kW)	A								
4,000 – 4,160 V²														
330 (246)	44	48	300 (224)	40	220 (164)	29	ACS 2040-1L-AN1-a-0C	280	1,940	2,500	1,940	2,500	n/a	n/a
385 (287)	52	57	350 (261)	47	257 (192)	34	ACS 2040-1L-AN1-a-0D	326	1,940	2,500	1,940	2,500	n/a	n/a
440 (328)	59	65	400 (298)	54	293 (218)	40	ACS 2040-1L-AN1-a-0E	373	1,940	2,500	1,940	2,500	n/a	n/a
495 (369)	67	74	450 (336)	61	330 (246)	45	ACS 2040-1L-AN1-a-0F	420	1,940	2,500	1,940	2,500	n/a	n/a
550 (410)	74	81	500 (373)	67	367 (274)	49	ACS 2040-1L-AN1-a-0H	466	1,940	2,500	1,940	2,500	n/a	n/a
660 (492)	89	98	600 (447)	81	440 (328)	59	ACS 2040-1L-AN1-a-0L	560	1,940	2,500	1,940	2,500	n/a	n/a
770 (574)	103	114	700 (522)	94	513 (383)	69	ACS 2040-1L-AN1-a-0Q	653	1,940	2,500	1,940	2,500	n/a	n/a
880 (656)	119	131	800 (597)	108	587 (438)	79	ACS 2040-1L-AN1-a-0R	746	1,940	2,500	1,940	2,500	n/a	n/a
945 (705)	127	140	900 (671)	121	660 (492)	85	ACS 2040-1L-AN1-a-0T	839	1,940	2,500	1,940	2,500	n/a	n/a
1000 (746)	135	149	1000 (746)	135	733 (547)	90	ACS 2040-1L-AN1-a-0V	933	1,940	2,500	1,940	2,500	n/a	n/a
1375 (1026)	185	203	1250 (933)	168	916 (684)	123	ACS 2040-2L-AN1-a-0Z	1,166	2,915	3,000	2,915	3,000	n/a	n/a
1650 (1230)	222	244	1500 (1119)	202	1100 (820)	148	ACS 2040-2L-AN1-a-1C	1,399	2,915	3,000	2,915	3,000	n/a	n/a
1925 (1437)	260	266	1750 (1306)	236	1283 (958)	173	ACS 2040-2L-AN1-a-1F	1,632	2,915	3,000	2,915	3,000	n/a	n/a
2000 (1492)	269	296	2000 (1492)	269	1647 (1094)	197	ACS 2040-2L-AN1-a-1H	1,865	2,915	3,000	2,915	3,000	n/a	n/a
2475 (1847)	333	367	2250 (1679)	303	1650 (1231)	222	ACS 2040-3L-AN1-a-1J	2,099	3,485	3,500	3,485	3,500	n/a	n/a
2750 (2051)	371	408	2500 (1856)	337	1833 (1368)	247	ACS 2040-3L-AN1-a-1N	2,332	3,485	3,500	3,485	3,500	n/a	n/a
2888 (2155)	389	427	2750 (2052)	370	1925 (1436)	259	ACS 2040-3L-AN1-a-2A	2,565	3,485	3,500	3,485	3,500	n/a	n/a
3000 (2238)	404	444	3000 (2238)	404	2200 (1641)	269	ACS 2040-3L-AN1-a-2B	2,798	3,485	3,500	3,485	3,500	n/a	n/a

Notes:

¹ Indicative information referring to typical 4-pole motor, under nominal supply voltage conditions. The ratings apply at 40°C. At higher temperatures (up to 50°C) the derating is 1.5% / 1°C. ² 4.16kV, +10% to -10%

No-overload use

$P_{cont. max}$: Typical motor power in no-overload use.

Nominal ratings

$I_{cont. max}$: Rated current available continuously without overloadability at 40°C.

I_{max} : Maximum output current, available for 10 seconds at start.

Light-overload use

P_N : Typical motor power in light-overload use.

I_N : Continuous current rating of particular sub-frame allowing 110% I_N at 40°C for 1 minute every 10 minutes.

Heavy-duty use

P_{hd} : Typical motor power in heavy-duty use.

I_{hd} : Continuous current rating of particular sub-frame allowing 150% I_{hd} at 40°C for 1 minute every 10 minutes.

Dimensions:

Height: 2,110 mm cabinet height

2,285 - 2,490 mm (incl. cooling fans on top)

2,490 - 2,515 mm with redundant cooling fans

Depth: 1,185 mm

Data sheet ACS 2000, 6.0 kV, low harmonic drive

Motor data ¹							Converter data		Converter length and weight (approx. values)					
									direct-to-line		for operation with external transformer		with integrated transformer	
No over-load	Nominal rating		Light overload		Heavy duty		Type code ²	Power	Length	Weight	Length	Weight	Length	Weight
P _{cont. max}	I _{cont. max}	I _{max}	P _N	I _N	P _{hd}	I _{hd}								
kW	A	A	kW	A	kW	A		kVA	mm	kg	mm	kg	mm	kg
6,000 V³														
275	33	36	250	30	183	22	ACS 2060-1x-AN1-a-0D	344	2,205	2,500	1,730	1,500	3,330 ⁴	3,050
347	42	46	315	38	231	28	ACS 2060-1x-AN1-a-0E	434	2,205	2,500	1,730	1,500	3,330 ⁴	3,100
390	47	52	355	43	260	31	ACS 2060-1x-AN1-a-0G	488	2,205	2,500	1,730	1,500	3,330 ⁴	3,150
440	53	58	400	48	293	35	ACS 2060-1x-AN1-a-0J	550	2,205	2,500	1,730	1,500	3,630	3,220
495	60	65	450	54	330	40	ACS 2060-1x-AN1-a-0L	619	2,205	2,500	1,730	1,500	3,630	3,220
550	66	73	500	60	367	44	ACS 2060-1x-AN1-a-0N	688	2,205	2,500	1,730	1,500	3,630	3,600
616	74	82	560	67	411	49	ACS 2060-1x-AN1-a-0Q	770	2,205	2,500	1,730	1,500	3,630	3,720
693	83	92	630	76	462	56	ACS 2060-1x-AN1-a-0S	866	2,205	2,500	1,730	1,500	3,630	3,850
781	94	100	710	85	521	63	ACS 2060-1x-AN1-a-0U	976	2,205	2,500	1,730	1,500	3,630	4,000
800	96	100	730	87	533	64	ACS 2060-1x-AN1-a-0V	1,000	2,205	2,500	1,730	1,500	3,630	4,000
880	108	116	800	96	587	71	ACS 2060-2x-AN1-a-0W	1,100	3,800	4,260	2,180	1,800	4,080 ⁴	4,550
990	119	131	900	108	660	79	ACS 2060-2x-AN1-a-0Y	1,238	3,800	4,260	2,180	1,800	4,080 ⁴	4,770
1100	132	146	1000	120	733	88	ACS 2060-2x-AN1-a-1A	1,375	3,800	4,260	2,180	1,800	4,080 ⁴	4,870
1232	148	163	1120	135	821	99	ACS 2060-2x-AN1-a-1C	1,540	3,800	4,260	2,180	1,800	4,380	5,140
1386	167	183	1260	152	924	111	ACS 2060-2x-AN1-a-1E	1,733	3,800	4,260	2,180	1,800	4,380	5,810
1562	188	200	1420	171	1041	125	ACS 2060-2x-AN1-a-1G	1,953	3,800	4,260	2,180	1,800	4,380	5,950
1760	212	233	1600	192	1173	141	ACS 2060-3x-AN1-a-1J	2,200	n/a	n/a	2,530	2,100	4,730 ⁵	5,410
1980	238	262	1800	217	1320	159	ACS 2060-3x-AN1-a-1N	2,475	n/a	n/a	2,530	2,100	4,930	5,650
2200	265	291	2000	241	1467	176	ACS 2060-3x-AN1-a-2A	2,750	n/a	n/a	2,530	2,100	4,930	5,850

Notes:

¹ Indicative information referring to typical 4-pole motor, under nominal supply voltage conditions. The ratings apply at 40°C. At higher temperatures (up to 50°C) the derating is 1.5% / 1°C.

No-overload use

P_{cont. max}: Typical motor power in no-overload use.

Nominal ratings

I_{cont. max}: Rated current available continuously without overloadability at 40°C.

I_{max}: Maximum output current, available for 10 seconds at start.

Light-overload use

P_N: Typical motor power in light-overload use.

I_N: Continuous current rating of particular sub-frame allowing 110% I_N at 40°C for 1 minute every 10 minutes.

Heavy-duty use

P_{hd}: Typical motor power in heavy-duty use.

I_{hd}: Continuous current rating of particular sub-frame allowing 150% I_{hd} at 40°C for 1 minute every 10 minutes.

² 'x' indicates the different converter types

B - for operation with external transformer

L - direct-to-line

K - with integrated transformer

³ AFE: 6.0 / 6.6 kV, -10% to +10%; 6.9 kV, -10% to +5%

DFE: 6.0 / 6.6 kV, -10% to +10%; 6.9 kV, 0% to +5%

⁴ Values for 6.6 kV primary voltage (>6.6 kV to 12 kV: +300 mm)

⁵ Values for 6.6 kV primary voltage (>6.6 kV to 12 kV: +200 mm)

Dimensions:

Height: 2,100 mm cabinet height

2,490 mm (incl. cooling fans on top)

2,700 mm with redundant cooling fans

Depth: 1,140 mm

Data sheet ACS 2000, 6.6 – 6.9 kV, low harmonic drive

Motor data ¹							Converter data		Converter length and weight (approx. values)					
									direct-to-line		for operation with external transformer		with integrated transformer	
No overload	Nominal rating		Light overload		Heavy duty		Type code ²	Power	Length	Weight	Length	Weight	Length	Weight
$P_{cont. max}$	$I_{cont. max}$	I_{max}	P_N	I_N	P_{hd}	I_{hd}								
kW	A	A	kW	A	kW	A		kVA	mm	kg	mm	kg	mm	kg
6,600 - 6,900 V³														
275	30	33	250	27	183	20	ACS 206y-1x-AN1-a-0D	344	2,205	2,500	1,730	1,500	3,330 ⁴	3,050
347	38	42	315	34	231	25	ACS 206y-1x-AN1-a-0E	434	2,205	2,500	1,730	1,500	3,330 ⁴	3,100
390	43	47	355	39	260	28	ACS 206y-1x-AN1-a-0G	488	2,205	2,500	1,730	1,500	3,330 ⁴	3,150
440	48	43	400	44	293	32	ACS 206y-1x-AN1-a-0J	550	2,205	2,500	1,730	1,500	3,630	3,220
495	54	60	450	49	330	36	ACS 206y-1x-AN1-a-0L	619	2,205	2,500	1,730	1,500	3,630	3,220
550	60	66	500	55	367	40	ACS 206y-1x-AN1-a-0N	688	2,205	2,500	1,730	1,500	3,630	3,600
616	67	74	560	61	411	45	ACS 206y-1x-AN1-a-0Q	770	2,205	2,500	1,730	1,500	3,630	3,720
693	76	83	630	69	462	51	ACS 206y-1x-AN1-a-0S	866	2,205	2,500	1,730	1,500	3,630	3,850
781	84	94	710	78	521	57	ACS 206y-1x-AN1-a-0U	976	2,205	2,500	1,730	1,500	3,630	4,000
820	94	100	730	85	547	62	ACS 206y-1x-AN1-a-0V	1,075	2,205	2,500	1,730	1,500	3,630	4,000
990	108	119	900	98	660	72	ACS 206y-2x-AN1-a-0Y	1,238	3,800	4,260	2,180	1,800	4,080 ⁴	4,770
1100	120	132	1000	109	733	80	ACS 206y-2x-AN1-a-1A	1,375	3,800	4,260	2,180	1,800	4,080 ⁴	4,870
1232	135	148	1120	122	821	90	ACS 206y-2x-AN1-a-1C	1,540	3,800	4,260	2,180	1,800	4,380	5,140
1386	152	167	1260	138	924	101	ACS 206y-2x-AN1-a-1E	1,733	3,800	4,260	2,180	1,800	4,380	5,810
1562	171	188	1420	155	1041	114	ACS 206y-2x-AN1-a-1G	1,953	3,800	4,260	2,180	1,800	4,380	5,950
1650	180	198	1500	164	1100	120	ACS 206y-2x-AN1-a-1H	2,063	3,800	4,260	2,180	1,800	4,380	5,950
1760	192	212	1600	175	1173	128	ACS 206y-3x-AN1-a-1J	2,200	n/a	n/a	2,530	2,100	4,730 ⁵	5,410
1980	217	238	1800	197	1320	144	ACS 206y-3x-AN1-a-1N	2,475	n/a	n/a	2,530	2,100	4,930	5,650
2200	241	265	2000	219	1467	160	ACS 206y-3x-AN1-a-2A	2,750	n/a	n/a	2,530	2,100	4,930	5,850
2464	269	296	2240	245	1643	180	ACS 206y-3x-AN1-a-2C	3,080	n/a	n/a	2,530	2,100	4,930	6,150

Notes:

¹ Indicative information referring to typical 4-pole motor, under nominal supply voltage conditions. The ratings apply at 40°C. At higher temperatures (up to 50°C) the derating is 1.5% / 1°C.

No-overload use

$P_{cont. max}$: Typical motor power in no-overload use.

Nominal ratings

$I_{cont. max}$: Rated current available continuously without overloadability at 40°C.

I_{max} : Maximum output current, available for 10 seconds at start.

Light-overload use

P_N : Typical motor power in light-overload use.

I_N : Continuous current rating of particular sub-frame allowing 110% I_N at 40°C for 1 minute every 10 minutes.

Heavy-duty use

P_{hd} : Typical motor power in heavy-duty use.

I_{hd} : Continuous current rating of particular sub-frame allowing 150% I_{hd} at 40°C for 1 minute every 10 minutes.

² 'x' indicates the different converter types

B - for operation with external transformer

L - direct-to-line

K - with integrated transformer

'y' indicates the different voltages

6 - for 6.6 kV

9 - for 6.9 kV

³ AFE: 6.0 / 6.6 kV, -10% to +10%; 6.9 kV, -10% to +5%

DFE: 6.0 / 6.6 kV, -10% to +10%; 6.9 kV, 0% to +5%

⁴ Values for 6.6 kV primary voltage (>6.6 kV to 11 kV: +300 mm)

⁵ Values for 6.6 kV primary voltage (>6.6 kV to 12 kV: +200 mm)

Dimensions:

Height: 2,100 mm cabinet height

2,490 mm (incl. cooling fans on top)

2,700 mm with redundant cooling fans

Depth: 1,140 mm

Data sheet ACS 2000, 4.0 – 4.16 kV, regenerative drive

Motor data ¹							Converter data		Converter length and weight (approx. values)					
									direct-to-line		for operation with external transformer		with integrated transformer	
No overload	Nominal rating		Light overload		Heavy duty		Type code	Power	Length	Weight	Length	Weight	Length	Weight
P _{cont. max}	I _{cont. max}	I _{max}	P _N	I _N	P _{hd}	I _{hd}		kVA	mm	kg	mm	kg	mm	kg
hp (kW)	A	A	hp (kW)	A	hp (kW)	A								
4,000 – 4,160 V²														
330 (246)	44	48	300 (224)	40	220 (164)	29	ACS 2040-1T-AN1-a-0C	280	1,940	2,500	1,940	2,500	n/a	n/a
385 (287)	52	57	350 (261)	47	257 (192)	34	ACS 2040-1T-AN1-a-0D	326	1,940	2,500	1,940	2,500	n/a	n/a
440 (328)	59	65	400 (298)	54	293 (218)	40	ACS 2040-1T-AN1-a-0E	373	1,940	2,500	1,940	2,500	n/a	n/a
495 (369)	67	74	450 (336)	61	330 (246)	45	ACS 2040-1T-AN1-a-0F	420	1,940	2,500	1,940	2,500	n/a	n/a
550 (410)	74	81	500 (373)	67	367 (274)	49	ACS 2040-1T-AN1-a-0H	466	1,940	2,500	1,940	2,500	n/a	n/a
660 (492)	89	98	600 (447)	81	440 (328)	59	ACS 2040-1T-AN1-a-0L	560	1,940	2,500	1,940	2,500	n/a	n/a
770 (574)	103	114	700 (522)	94	513 (383)	69	ACS 2040-1T-AN1-a-0Q	653	1,940	2,500	1,940	2,500	n/a	n/a
880 (656)	119	131	800 (597)	108	587 (438)	79	ACS 2040-1T-AN1-a-0R	746	1,940	2,500	1,940	2,500	n/a	n/a
945 (705)	127	140	900 (671)	121	660 (492)	85	ACS 2040-1T-AN1-a-0T	839	1,940	2,500	1,940	2,500	n/a	n/a
1000 (746)	135	149	1000 (746)	135	733 (547)	90	ACS 2040-1T-AN1-a-0V	933	1,940	2,500	1,940	2,500	n/a	n/a
1375 (1026)	185	203	1250 (933)	168	916 (684)	123	ACS 2040-2T-AN1-a-0Z	1,166	2,915	3,000	2,915	3,000	n/a	n/a
1650 (1230)	222	244	1500 (1119)	202	1100 (820)	148	ACS 2040-2T-AN1-a-1C	1,399	2,915	3,000	2,915	3,000	n/a	n/a
1925 (1437)	260	266	1750 (1306)	236	1283 (958)	173	ACS 2040-2T-AN1-a-1F	1,632	2,915	3,000	2,915	3,000	n/a	n/a
2000 (1492)	269	296	2000 (1492)	269	1647 (1094)	197	ACS 2040-2T-AN1-a-1H	1,865	2,915	3,000	2,915	3,000	n/a	n/a
2475 (1847)	333	367	2250 (1679)	303	1650 (1231)	222	ACS 2040-3T-AN1-a-1J	2,099	3,485	3,500	3,485	3,500	n/a	n/a
2750 (2051)	371	408	2500 (1856)	337	1833 (1368)	247	ACS 2040-3T-AN1-a-1N	2,332	3,485	3,500	3,485	3,500	n/a	n/a
2888 (2155)	389	427	2750 (2052)	370	1925 (1436)	259	ACS 2040-3T-AN1-a-2A	2,565	3,485	3,500	3,485	3,500	n/a	n/a
3000 (2238)	404	444	3000 (2238)	404	2200 (1641)	269	ACS 2040-3T-AN1-a-2B	2,798	3,485	3,500	3,485	3,500	n/a	n/a

Notes:

¹ Indicative information referring to typical 4-pole motor, under nominal supply voltage conditions. The ratings apply at 40°C. At higher temperatures (up to 50°C) the derating is 1.5% / 1°C.

² 4.16 kV, +10% to -10%

No-overload use

P_{cont. max}: Typical motor power in no-overload use.

Nominal ratings

I_{cont. max}: Rated current available continuously without overloadability at 40°C.

I_{max}: Maximum output current, available for 10 seconds at start.

Light-overload use

P_N: Typical motor power in light-overload use.

I_N: Continuous current rating of particular sub-frame allowing 110% I_N at 40°C for 1 minute every 10 minutes.

Heavy-duty use

P_{hd}: Typical motor power in heavy-duty use.

I_{hd}: Continuous current rating of particular sub-frame allowing 150% I_{hd} at 40°C for 1 minute every 10 minutes.

Dimensions:

Height: 2,110 mm cabinet height

2,285 - 2,490 mm (incl. cooling fans on top)

2,490 - 2,515 mm with redundant cooling fans

Depth: 1,185 mm

Data sheet ACS 2000, 6.0 kV, regenerative drive

Motor data ¹							Converter data		Converter length and weight (approx. values)					
									direct-to-line		for operation with external transformer		with integrated transformer	
No overload	Nominal rating		Light overload		Heavy duty		Type code ²	Power	Length	Weight	Length	Weight	Length	Weight
$P_{cont. max}$	$I_{cont. max}$	I_{max}	P_N	I_N	P_{hd}	I_{hd}								
kW	A	A	kW	A	kW	A		kVA	mm	kg	mm	kg	mm	kg
6,000 V³														
275	33	36	250	30	183	22	ACS 2060-1x-AN1-a-0D	344	2,205	2,500	1,705	1,550	3,405	2,850
347	42	46	315	38	231	28	ACS 2060-1x-AN1-a-0E	434	2,205	2,500	1,705	1,550	3,405	2,940
390	47	52	355	43	260	31	ACS 2060-1x-AN1-a-0G	488	2,205	2,500	1,705	1,550	3,405	3,030
440	53	58	400	48	293	35	ACS 2060-1x-AN1-a-0J	550	2,205	2,500	1,705	1,550	3,405	3,130
495	60	65	450	54	330	40	ACS 2060-1x-AN1-a-0L	619	2,205	2,500	1,705	1,550	3,405	3,230
550	66	73	500	60	367	44	ACS 2060-1x-AN1-a-0N	688	2,205	2,500	1,705	1,550	3,405	3,330
616	74	82	560	67	411	49	ACS 2060-1x-AN1-a-0Q	770	2,205	2,500	1,705	1,550	3,405	3,450
693	83	92	630	76	462	56	ACS 2060-1x-AN1-a-0S	866	2,205	2,500	1,705	1,550	3,405	3,580
781	94	100	710	85	521	63	ACS 2060-1x-AN1-a-0U	976	2,205	2,500	1,705	1,550	3,405	3,720
800	96	100	730	87	533	64	ACS 2060-1x-AN1-a-0V	1,000	2,205	2,500	1,705	1,550	3,405	3,750
880	108	116	800	96	587	71	ACS 2060-2x-AN1-a-0W	1,100	3,800	4,260	3,000	2,550	5,200	5,140
990	119	131	900	108	660	79	ACS 2060-2x-AN1-a-0Y	1,238	3,800	4,260	3,000	2,550	5,200	5,140
1100	132	146	1000	120	733	88	ACS 2060-2x-AN1-a-1A	1,375	3,800	4,260	3,000	2,550	5,200	5,300
1232	148	163	1120	135	821	99	ACS 2060-2x-AN1-a-1C	1,540	3,800	4,260	3,000	2,550	5,200	5,490
1386	167	183	1260	152	924	111	ACS 2060-2x-AN1-a-1E	1,733	3,800	4,260	3,000	2,550	5,200	5,700
1562	188	200	1420	171	1041	125	ACS 2060-2x-AN1-a-1G	1,953	3,800	4,260	3,000	2,550	5,200	5,940
1760	212	233	1600	192	1173	141	ACS 2060-3x-AN1-a-1J	2,200	n/a	n/a	n/a	n/a	n/a	n/a
1980	238	262	1800	217	1320	159	ACS 2060-3x-AN1-a-1N	2,475	n/a	n/a	n/a	n/a	n/a	n/a
2200	265	291	2000	241	1467	176	ACS 2060-3x-AN1-a-2A	2,750	n/a	n/a	n/a	n/a	n/a	n/a

Notes:

¹ Indicative information referring to typical 4-pole motor, under nominal supply voltage conditions. The ratings apply at 40°C. At higher temperatures (up to 50°C) the derating is 1.5% / 1°C.

No-overload use

$P_{cont. max}$: Typical motor power in no-overload use.

Nominal ratings

$I_{cont. max}$: Rated current available continuously without overloadability at 40°C.

I_{max} : Maximum output current, available for 10 seconds at start.

Light-overload use

P_N : Typical motor power in light-overload use.

I_N : Continuous current rating of particular sub-frame allowing 110% I_N at 40°C for 1 minute every 10 minutes.

Heavy-duty use

P_{hd} : Typical motor power in heavy-duty use.

I_{hd} : Continuous current rating of particular sub-frame allowing 150% I_{hd} at 40°C for 1 minute every 10 minutes.

² 'x' indicates the different converter types

A - for operation with external transformer

T - direct-to-line

I - with integrated transformer

³ AFE: 6.0 / 6.6 kV, -10% to +10%; 6.9 kV, -10% to +5%

Dimensions:

Height: 2,100 mm cabinet height

2,490 mm (incl. cooling fans on top)

2,700 mm with redundant cooling fans

Depth: 1,140 mm

Data sheet ACS 2000, 6.6 – 6.9 kV, regenerative drive

Motor data ¹							Converter data		Converter length and weight (approx. values)					
									direct-to-line		for operation with external transformer		with integrated transformer	
No over-load	Nominal rating		Light overload		Heavy duty		Type code ²	Power	Length	Weight	Length	Weight	Length	Weight
$P_{cont,max}$	$I_{cont,max}$	I_{max}	P_N	I_N	P_{hd}	I_{hd}								
kW	A	A	kW	A	kW	A		kVA	mm	kg	mm	kg	mm	kg
6,600 - 6,900 V³														
275	30	33	250	27	183	20	ACS 206y-1x-AN1-a-0D	344	2,205	2,500	1,705	1,550	3,405	2,850
347	38	42	315	34	231	25	ACS 206y-1x-AN1-a-0E	434	2,205	2,500	1,705	1,550	3,405	2,940
390	43	47	355	39	260	28	ACS 206y-1x-AN1-a-0G	488	2,205	2,500	1,705	1,550	3,405	3,030
440	48	43	400	44	293	32	ACS 206y-1x-AN1-a-0J	550	2,205	2,500	1,705	1,550	3,405	3,130
495	54	60	450	49	330	36	ACS 206y-1x-AN1-a-0L	619	2,205	2,500	1,705	1,550	3,405	3,230
550	60	66	500	55	367	40	ACS 206y-1x-AN1-a-0N	688	2,205	2,500	1,705	1,550	3,405	3,330
616	67	74	560	61	411	45	ACS 206y-1x-AN1-a-0Q	770	2,205	2,500	1,705	1,550	3,405	3,450
693	76	83	630	69	462	51	ACS 206y-1x-AN1-a-0S	866	2,205	2,500	1,705	1,550	3,405	3,580
781	84	94	710	78	521	57	ACS 206y-1x-AN1-a-0U	976	2,205	2,500	1,705	1,550	3,405	3,720
820	94	100	730	85	547	62	ACS 206y-1x-AN1-a-0V	1,075	2,205	2,500	1,705	1,550	3,405	3,750
990	108	119	900	98	660	72	ACS 206y-2x-AN1-a-0Y	1,238	3,800	4,260	3,000	2,550	5,200	5,140
1100	120	132	1000	109	733	80	ACS 206y-2x-AN1-a-1A	1,375	3,800	4,260	3,000	2,550	5,200	5,300
1232	135	148	1120	122	821	90	ACS 206y-2x-AN1-a-1C	1,540	3,800	4,260	3,000	2,550	5,200	5,490
1386	152	167	1260	138	924	101	ACS 206y-2x-AN1-a-1E	1,733	3,800	4,260	3,000	2,550	5,200	5,700
1562	171	188	1420	155	1041	114	ACS 206y-2x-AN1-a-1G	1,953	3,800	4,260	3,000	2,550	5,200	5,940
1650	180	198	1500	164	1100	120	ACS 206y-2x-AN1-a-1H	2,063	3,800	4,260	3,000	2,550	5,200	5,990
1760	192	212	1600	175	1173	128	ACS 206y-3x-AN1-a-1J	2,200	n/a	n/a	n/a	n/a	n/a	n/a
1980	217	238	1800	197	1320	144	ACS 206y-3x-AN1-a-1N	2,475	n/a	n/a	n/a	n/a	n/a	n/a
2200	241	265	2000	219	1467	160	ACS 206y-3x-AN1-a-2A	2,750	n/a	n/a	n/a	n/a	n/a	n/a
2464	269	296	2240	245	1643	180	ACS 206y-3x-AN1-a-2C	3,080	n/a	n/a	n/a	n/a	n/a	n/a

Notes:

¹ Indicative information referring to typical 4-pole motor, under nominal supply voltage conditions. The ratings apply at 40°C. At higher temperatures (up to 50°C) the derating is 1.5% / 1°C.

No-overload use

$P_{cont,max}$: Typical motor power in no-overload use.

Nominal ratings

$I_{cont,max}$: Rated current available continuously without overloadability at 40°C.

I_{max} : Maximum output current, available for 10 seconds at start.

Light-overload use

P_N : Typical motor power in light-overload use.

I_N : Continuous current rating of particular sub-frame allowing 110% I_N at 40°C for 1 minute every 10 minutes.

Heavy-duty use

P_{hd} : Typical motor power in heavy-duty use.

I_{hd} : Continuous current rating of particular sub-frame allowing 150% I_{hd} at 40°C for 1 minute every 10 minutes.

² 'x' indicates the different converter types

A - for operation with external transformer

T - direct-to-line

I - with integrated transformer

'y' indicates the different voltages

6 - for 6.6 kV

9 - for 6.9 kV

³ AFE: 6.0 / 6.6kV, -10% to +10%; 6.9kV, -10% to +5%

Dimensions:

Height: 2,100 mm cabinet height

2,490 mm (incl. cooling fans on top)

2,700 mm with redundant cooling fans

Depth: 1,140 mm

Notes

Contact us

For more information contact your local ABB representative
or visit:

www.abb.com/drives

